

AUT

Pump Control Valve PN10 / PN16 / PN25

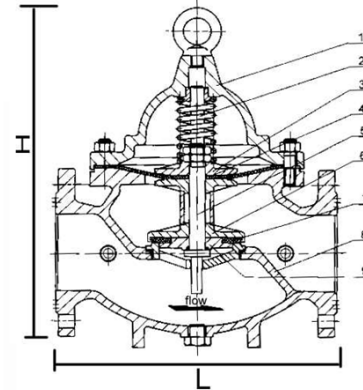

Parts

No.	Parts name	Material	Standard	Grade	Test			
					Nominal Pressure	PN10	PN16	PN25
1	Cover	Ductile iron	BS 2789	500/7	Shell Pressure	15 bars	24 bars	37.5 bars
2	Spring	Stainless steel	BS 970 - part 1	420S37	Seat Pressure	11 bars	17.6 bars	27.5 bars
3	Disc	Brass	BS 1400	AB1	Max .Temp	70 °C		
4	Diaphragm	Synthetic Rubber	BS 2494	EPDM				
5	Stem	Stainless steel / cast steel	BS 970 - part 1	420S37				
6	Disc	Ductile iron or brass / cast steel	BS 1400 / BS 1769	AB1				
7	Seal	Synthetic Rubber	BS 2494	EPDM				
8	Body	Ductile iron	BS 2789	500/7				
9	Seal disc	Gunmetal	BS 1400	LG2				

Designs

1	Flange face to face according to ANSI B16.10 / BS 1868 / ISO 5752 - 10
2	Flange drilled according to BS 4504 / DIN2501, PN10 / PN16 / PN25
3	Inspection and test according to BS 6755
4	Internal and external coating by fluid epoxy powder, more than 250 micron thickness

Dimensions

DN	L	H	Dimensions of Flange (PN10 / PN16 / PN25)			
			Dia. of flange	Nos. of hole	Dia. of hole	P.C.D.
			PN10 / PN16 / PN25	PN10 / PN16 / PN25	PN10 / PN16 / PN25	PN10 / PN16 / PN25
80	250	320	200 / 200 / 200	4 / 8 / 8	18 / 18 / 18	160 / 160 / 160
100	292	325	220 / 220 / 235	8 / 8 / 8	18 / 18 / 23	180 / 180 / 190
150	356	430	285 / 285 / 300	8 / 8 / 8	23 / 23 / 27	240 / 240 / 250
200	457	520	340 / 340 / 360	8 / 12 / 12	23 / 23 / 27	295 / 295 / 310
250	585	750	395 / 405 / 425	12 / 12 / 12	23 / 27 / 30	350 / 355 / 370
300	650	913	445 / 460 / 485	12 / 12 / 16	23 / 27 / 30	400 / 410 / 430
400	960	1035	565 / 580 / 620	16 / 16 / 16	27 / 30 / 36	515 / 525 / 550

AUT RESOURCES SDN BHD (768928D)
 43 GREEN DRIVE 11600 PENANG MALAYSIA
 PHONE : 60124210032, 60124238009 FAX : 6046439708
 E-mail : access_ustrade@yahoo.com. / write2us@autresources.com
<http://www.autresources.com/>